

XC-ST Series

CCD B/W Video Camera Module
Non-TV Format



IMAGE SENSING SOLUTIONS

The XC-ST Series cameras incorporate the innovative CCD and signal processing technologies into a compact black and white camera module.

XC-ST30/ST30CE, XC-ST50/ST50CE, XC-ST51/ST51CE, XC-ST70/ST70CE

Features

A new external trigger design allows the electronic shutter speed to be freely specified by the width of an external trigger pulse or by a switch setting on the rear panel of the camera.

These cameras are also user-friendly, with all switch settings located on the rear panel.

Moreover, the 1/3 type CCD, 1/2 type CCD and 2/3 type CCD models have the exact same dimensions, simplifying space requirements and making it easy to interchange them if necessary. These features, along with high picture quality and high shock and vibration tolerance make the XC-ST Series cameras ideal for demanding machine vision applications.

- 2/3 type IT CCD : XC-ST70/ST70CE
- 1/2 type IT CCD : XC-ST51/ST51CE
- 1/2 type IT CCD : XC-ST50/ST50CE
- 1/3 type IT CCD : XC-ST30/ST30CE
- **Small and lightweight:** 44 (W) × 29 (H) × 57.5 (D) mm, Approx. 110 g (XC-ST70/ST70CE is 105 g)
- **High sensitivity :**
 - 0.3 lx (F1.4) : XC-ST70/ST70CE, XC-ST50/ST50CE and XC-ST30/ST30CE
 - 0.2 lx (F1.4) : XC-ST51/ST51CE
- **High S/N ratio**
 - 54 dB : XC-ST30CE
 - 56 dB : XC-ST30
 - 58 dB : XC-ST50CE, XC-ST51CE, XC-ST70CE
 - 60 dB : XC-ST50, XC-ST51, XC-ST70
- **Electronic shutter function (1/100 to 1/10,000 s)**
- **Flexible trigger shutter functions**
- **Readout on Commande (with HD/VD input)**
- **2:1 interface**
- **Synchronisation: internal/external (HD/VD, VS)**
- **Frame/Field exposure**
- **Restart/Reset function**
- **High shock and vibration tolerant**

XC-ST30/ST30CE , XC-ST50/ST50CE

XC-ST51/ST51CE XC-ST70/ST70CE

Connections

C mount lens

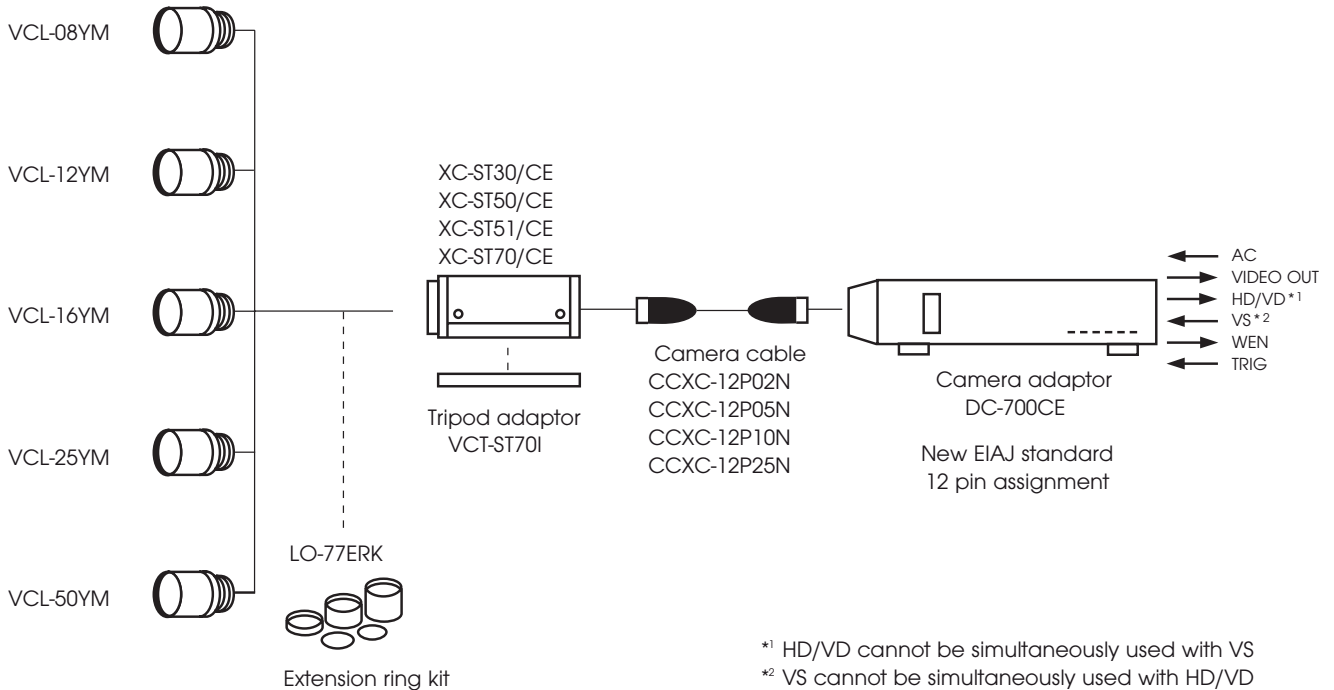

Locations of Parts & Operations

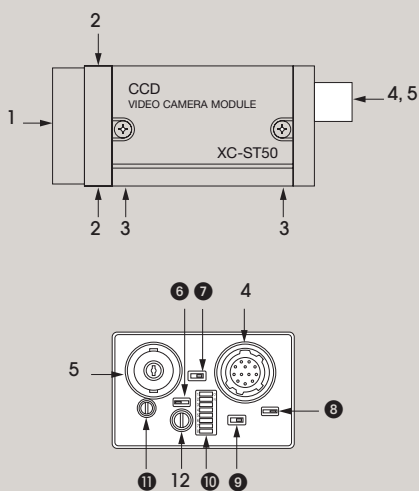

1. Lens mount (C mount)

A commercial C mount lens as well as Sony standard lenses can be used.

2. Camera fixing reference hole

High-precision screw hole machined on the lens mount surface.

3. Screw hole for tripod adaptor installation (VCT-ST70I)

The 12 pin multi-connector is connected to a DC IN/SYNC (DC power/sync signal input)

5. BNC connector

Video out

6. Gamma correction

ON/OFF switchable

7. Internal/External synchronisation switch

In the EXT position, if there is no external sync input, the internal sync is activated inside the camera. In this case, HD/VD signal is not output through the 12 pin multi-connector.

8. Trigger polarity switch

The trigger polarity is selectable (neg/pos polarity)

9. 75 Ω termination switch

10. Dip switch

Dip switch 1 - 4: Shutter speed
Dip switch 5: FRAME/FIELD exposure
Dip switch 6 - 8: Normal shutter mode, External trigger shutter mode, Restart/Reset mode

11. Gain switch

A: Image output at a fixed level of image according to the brightness of the subject. (Variable range: 0 to 18 dB)
F: Fixed gain 0 dB
M: gain (manual)
Factory setting: the variable gain is adjusted to the fixed sensitivity for a standard subject. When using two or more XC-ST30/CE, XC-ST50/CE, XC-ST51/CE or XC-ST70/CE cameras, identical images of the same subject can be attained.

12 Gain control

The gain can be adjusted between 0 to 18 dB when the gain switch is set to "M".

Rear Panel factory settings

No.	Switch	Factory setting	
6	Gamma correction ON/OFF	OFF	
7	Internal/External sync	EXT	
8	Trigger polarity	+	
9	75 Ω termination	ON	
10	Dip switch	1 · 2 · 3 · 4: Shutter speed	OFF
		5: Field/Frame	OFF
		6 · 7 · 8: normal shutter/EXT trigger shutter/restart reset	OFF
11	GAIN	FIX	

12 pin multi-connector

Pin No.	Internal HD/VD sync	External HD/VD sync	External C. sync
1		GND	
2		+12 V	
3		GND	
4		VIDEO output	
5	GND	VD input (Ground)	Reset (Ground)
6	Internal HD output	External HD input	-
7	Internal VD output	*3 External VD input	VS input
8		GN	
9		-	
10		*4 WEN output	
11		TRIG input	
12		GN	

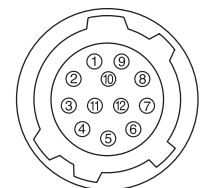

*3 : In Restart/Reset mode VD input is necessary

*4 : WEN output is only effective in EXT trigger shutter mode

Trigger Shutter Modes

A new external trigger design allows the electronic shutter speed to be freely specified by the width of an external trigger pulse or by a switch setting on the rear panel of the camera.

Shutter speed setting based on the trigger width

Non reset mode Ext sync (continuous HD/continuous VD input), or internal sync

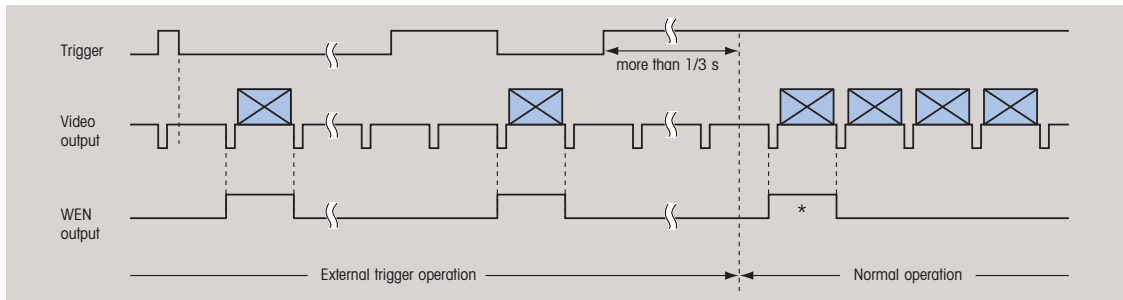

Non reset mode Ext sync (continuous HD and single VD input)

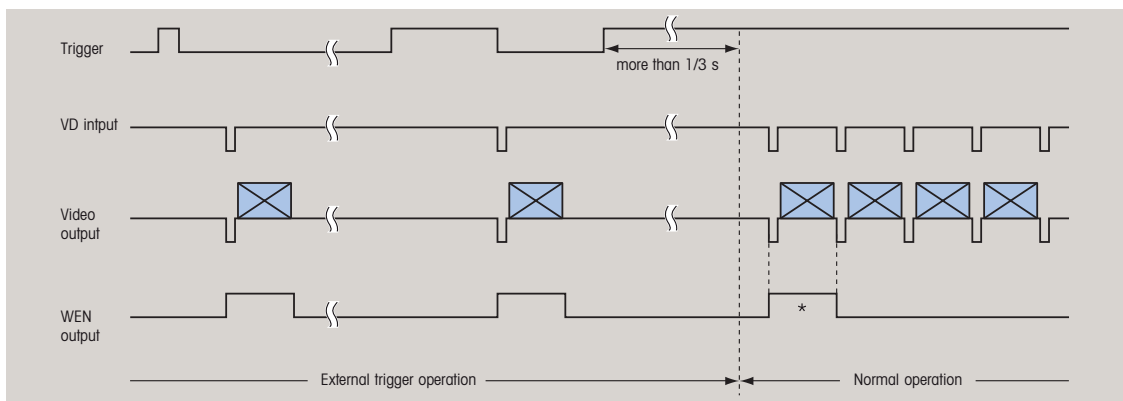

Reset mode Only for Ext sync

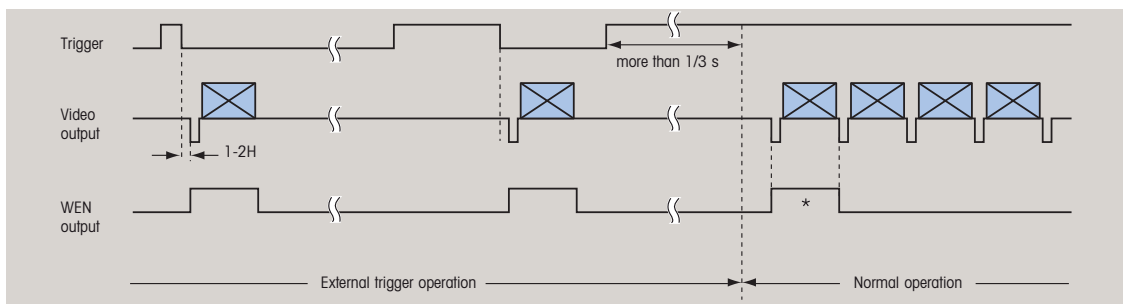

* When switching from Ext. trigger to regular operation the WEN pulse is output

Shutter speed settings by dip switch control

Shutter speeds are set by dip switches 6, 7, 8, on the camera's rear panel. The width of the trigger pulse is irrelevant.

Accessories

Compact camera adaptor

DC-700
DC-700CE



- Compact, lightweight (700 g)
- Two video outputs
- External sync IN/OUT
- Trigger input/WEN output
- New EIAJ standard 12-pin connector
- Dimensions:
110 (W) x 53 (H) x 160 (D) mm

12-pin camera cable (CE standard)

CCXC-12P02N (2 m)
CCXC-12P05N (5 m)
CCXC-12P10N (10 m)
CCXC-12P25N (25 m)



Tripod Adaptor

VCT-ST701

- Isolated type
- Approx. 14 g
- Dimensions: 40 (W) x 6 (H) x 59 (D) mm

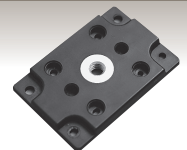

Junction Box

JB-77



Specifications

	XC-ST30	XC-ST50	XC-ST51	XC-ST70	XC-ST30CE	XC-ST50CE	XC-ST51CE	XC-ST70CE
Image device	1/3 type IT CCD	1/2 type IT CCD	1/2 type IT CCD	2/3 type IT CCD	1/3 type IT CCD	1/2 type IT CCD	1/2 type IT CCD	2/3 type IT CCD
Effective pictures elements	768 (H) x 494 (V)				752 (H) x 582 (V)			
Signal system	EIA standard				CCIR standard			
Horizontal frequency	15.734 kHz ±1%				15.625 kHz ±1%			
Vertical frequency	59.94 Hz				50 Hz			
Lens mount	C mount							
Flange back	17.526 mm							
Sync system	Internal / External (auto)							
External Sync system	HD / VD (2 ~ 5 Vp-p), VS							
External Sync frequency	Horizontal sync frequency ± 1%							
Jitter	less than ± 50 nsec							
Scanning system	525 lines, 60 fields/s, 2:1 Interlaced				625 lines, 50 fields/s, 2:1 Interlaced			
Video output	1.0 Vp-p, negative, 75 Ω unbalanced							
Horizontal resolution	570 TV lines				560 TV lines			
Sensitivity (γ compensation ON, 0 dB)	400 lx, F5.6	400 lx, F8	400 lx, F11	400 lx, F8	400 lx, F5.6	400 lx, F8	400 lx, F11	400 lx, F8
Minimum illumination (F1.4 AGC ON, without IR cut filter)	0.3 lx		0.2 lx	0.3 lx	0.3 lx		0.2 lx	0.3 lx
S/N ratio	56 dB	60 dB			54 dB	58 dB		
Gain AGC	(0 ~ 18 dB) / Manual (0 ~ 18 dB) / Fixed (0 dB) Selectable							
Gamma	ON / OFF							
Normal shutter	1/100 ~ 1/10,000 s				1/120 ~ 1/10,000 s			
External trigger shutter	1/4 ~ 1/10,000 s				1/4 ~ 1/8,000 s			
Power requirements	DC 12 V ±10%							
Power consumption	1.9 W	2.0 W		2.1 W	1.9 W	2.0 W		2.1 W
Dimensions	44 (W) x 29 (H) x 57.5 (D) mm							
Mass	110 g		105 g		110 g		105 g	
Operation temp. /Humidity	-5°C ~ +45°C / 20 ~ 80%							
Storage temp. /Humidity	-30°C ~ +60°C / 20 ~ 95%							
Vibration	10 G (20 ~ 200 Hz)							
Shock resistance	70 G							
MTBF	70,600 hrs.							
Regulations	UL6500, FCC Class B, IC Class B, CE (EN61326/97 + A1/98), AS4251.1 + AS4252.2							
Supplied accessories	Lens mount cap (x 1), Operating instructions (x 1)							
Optional accessories	DC-700CE: Compact camera adaptor (CE standard); Compact, lightweight, Two video outputs, External sync IN/OUT, Trigger input/WEN output, New EIAJ standard 12 pin assignment, Dimensions: 110 (W) x 53 (H) x 160 (D) mm CCXC-12P02N (2 m), CCXC-12P05N (5 m), CCXC-12P10N (10 m), CCXC-12P25N (25 m): 12 pin camera cable (CE standard) VCT-ST70I: Tripod adaptor: Isolated type, Approx. 14 g, Dimensions: 40 (W) x 6 (H) x 59 (D) mm							

Dimensions

XC-ST30/ST30CE, XC-ST50/ST50CE, XC-ST51/ST51CE, XC-ST70/ST70CE

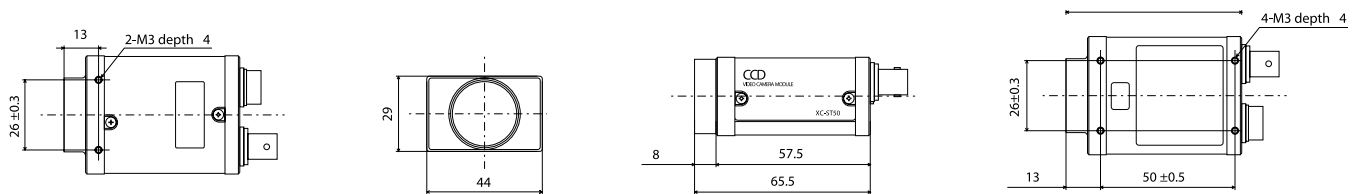

Unit: mm

Distributed by

© 2010 Sony Corporation. All rights reserved. Reproduction in whole or in part without written permission is prohibited. Features and specifications are subject to change without notice. The values for mass and dimension are approximate. Sony is a registered trademark of Sony Corporation. Super HAD CCD II is a trademark of Sony Corporation. All other properties are the property of their respective owners.

SONY
make.believe